



# MECAMARC

*Labelling machine designer since 1966*

## M2 - SEMI-AUTOMATIC LABELLING MACHINE



*Photo without contractual value*



Production rate up to 650 bottles/hour

Bottle dimensions: diameter 55 mm to 115 mm

Bottle height: until 380 mm

Bottle capacity: from 33cl to Magnum, without tool change

Different composition of contents\*: glass, PER, PVC or aluminium cans.

Digital display

\*Subject to the resistance of the materials

### TYPE OF CONTENTS

Sparkling wines:

- ▶ Half,
- ▶ Standard,
- ▶ Magnum,
- ▶ Specific bottles.

Up to 3 label dispensers

Digital display

Capsuling system

Capsule orientation

A rotative reception table ø500



## LABELLING

Up to 3 label dispensers (up to 4 labels)

- ▶ Label (possibility label and back label on the same roll)
- ▶ Back label
- ▶ Third label or medal or neck label or seal

Maximum label height: 200 mm



Manual adjustment of the label positioning

Stepper motor for more precision

Winding direction: left out



## CAPSULE DISPENSER

Manual capsule dispenser

## CAPSULING

Monobloc champagne capsuling system

Capsule dimensions:

- ▶ Length up to 135 mm

## OPTIONS

Transparent label detection by ultrason cell

Markers:

- ▶ Ink jet marker
- ▶ Incision marker
- ▶ Heat marker

Bottle orientation for foil positioning:

- ▶ UV spot
- ▶ Color spot

Spotting system:

- ▶ UV Spot
- ▶ Color spot
- ▶ Notched bottles
- ▶ Already labelled bottles
- ▶ Mold seal

Reception table: rectangular or rotating (diameter 700mm)

Machine on 4 wheels

Additional conveyor lenght

Machine will stop in the event of a jam at the outlet

## DIGITAL DISPLAY

Easy to use and intuitive

Storage of 100 label positions

Easy to create a new label position

Remote control diagnoses system (live link)

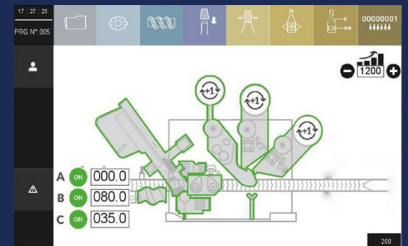

## ASSETS

Design

Mechanical cam for high quality capsuling

Scalable labelling machine

Inox 304L composition

Ultra resistant powder coated machine skeleton to prevent corrosion over time

CE standardized labelling machine certified by an independent organization

Reinforced electrical protection (safety module, protection of components independently)

Latest generation automation



# TECHNICAL ELEMENTS

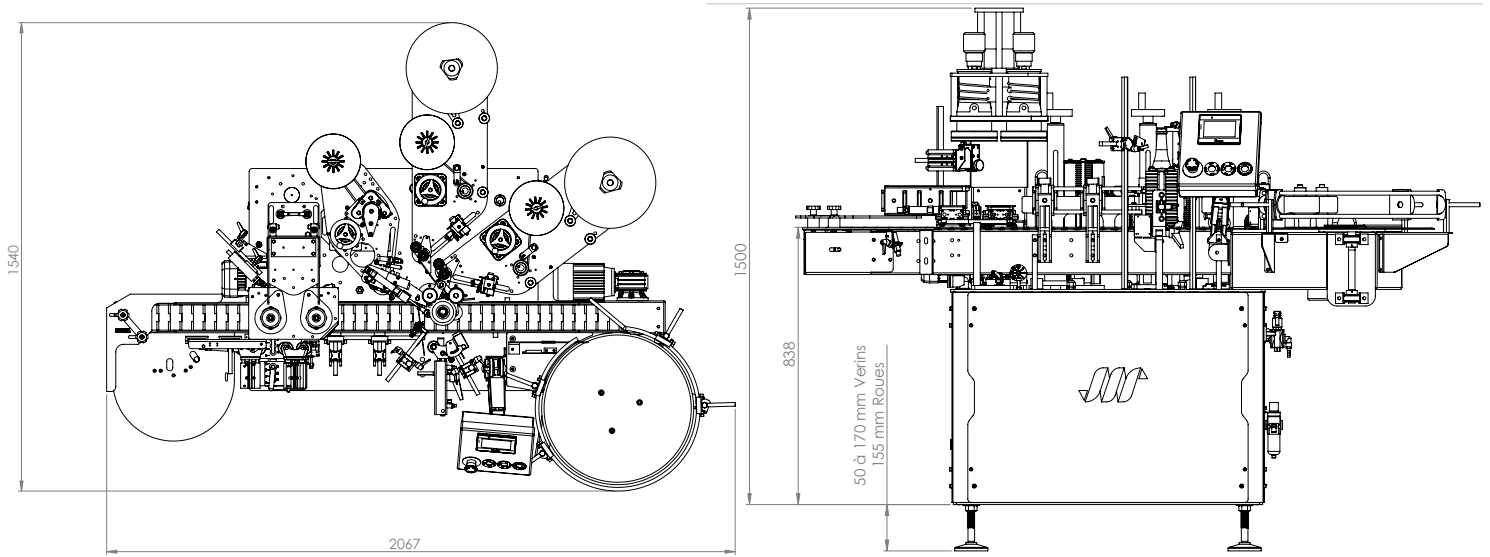

<b>Weight (kgs):</b>	200 (variable depending on the equipments)
<b>Power supply:</b>	380V three-phase ~ 50 Hz 3 phases + earth <b>Intensity: 16 A , Pressure: 6 bars</b>
<b>Air consumption:</b>	10 m <sup>3</sup> /h under 6 bars - non-lubricated dry air

## STANDARD CONFIGURATION

- One label dispenser
- Acetal slate band conveyor width 82,5mm / 3,25in
- Adjustable stainless steel side guides
- Ratchet system for bottle timing
- Rectangular reception table, diameter 500 mm
- Labeler on 4 feet

**GARANTIE 1 AN – MADE IN FRANCE**



MECAMARC  
LA PIERRE QUI TOURNE - 51480 ŒUILLY - FRANCE

TÈL. +33 (0)3 26 58 18 18

WWW.MECAMARC.COM

